

**WARNING:** Moving parts, beware of entrapment areas

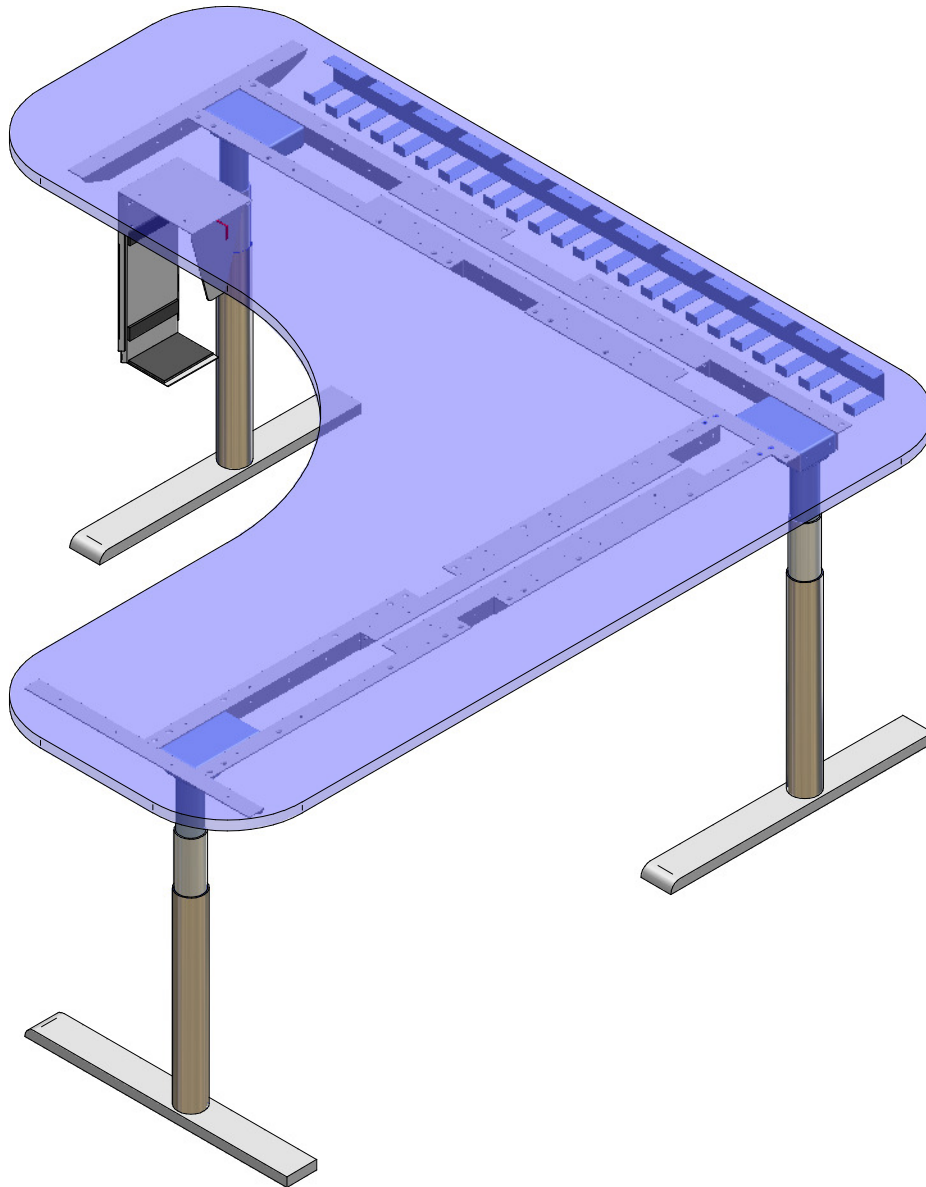

**motiondesk3-DL14**

660mm electric adjustment  
580mm to 1240mm (from floor level)  
200kg total lift capacity  
15 seconds from sit to stand  
Optional multiple Memory positions  
Optional cable tray  
Optional CPU Holder  
Piezo Anti-Collision built into system  
Available to suit all desk sizes  
Frames available in black and white  
10 year warranty on frame and electrics

© Copyright all rights reserved.  
This drawing is the property of Ergomotion Pty Ltd. It may not be copied in whole or part nor can it be used for the manufacture of any equipment described without written permission of Ergomotion.

Customer:

Date:

**ergomotion**

PO Box 234, East Bentleigh, VIC, 3165  
+61 3 95791454

**TITLE: motiondesk3-DL14**

Designed by Guy Topolansky